

UNDERGROUND DRILLING RIG C600

SDS

SOLID DRILLING SOLUTIONS



TECHNICAL OVERVIEW



C600 UNDERGROUND DRILLING RIG



- **MOBILITY** - The C600 Underground Drilling Rig is equipped with a 360-degree drilling mast. Options are available for skid or crawler travel. Also, as an addition to the crawler, it is possible to equip it with a stand-alone diesel engine.
- **RELIABILITY** - Ease of operation and maintenance maximizes plant convenience and efficiency
- **SAFETY** - The C600 Underground Drilling Rig is designed for long-term operations, taking into account the prevention of possible safety risks.



C600 UNDERGROUND DRILLING RIG



CONTROL PANEL - FUNCTIONAL PANEL DESIGN, PROVIDES EASY OPERATION.

HYDRAULIC DESIGN - LOAD-SENSITIVE HYDRAULIC SYSTEM SUPPORTS ENERGY SAVING.

MAST - 360° DRILLING CAPABILITY IN ANY PART OF THE MINE WORKINGS.

SYNCHRONIZATION - THE PIPE HOLDER AND ROTATOR WORK SYNCHRONOUSLY THANKS TO THE VALVE BLOCK DESIGN. THIS FEATURE ENSURES FAST AND SAFE DRILLING.



ROTATION UNIT - THE FUNCTIONAL DESIGN OF THE ROTATOR ALLOWS WORKING WITH DIAMETERS FROM B TO N

CATERPILLAR BASE - WITH OPTION TO DRIVE INDEPENDENT DIESEL ENGINE TO POWER THE TRACK YOU GET MORE FREEDOM OF MOVEMENT IN UNDERGROUND CONDITIONS.



DRILLING RECOMMENDATIONS

DRILLING DEPTH HOWL (MAX.)	500M
DRILLING DEPTH NOWL (MAX.)	750M
DRILLING DEPTH BOWL (MAX.)	1000M

CSK CANNOT GUARANTEE THAT THE INDICATED DEPTHS WILL BE REACHED IN ALL DRILLING CONDITIONS DUE TO VARIOUS FACTORS, SUCH AS THE SUBMERSIBLE DRILLING TECHNOLOGY USED, GROUND CONDITIONS, AND OPERATING CONDITIONS.

MAIN PUMPS	DANFOSS OR ANALOG.
SERVICE PUMP	DANFOSS, SALAMI, GALTECH
ROTATION UNIT MOTOR	REXROTH OR ANALOG.
ROTATION SPEED	25-1200 RPM
MAX. TORQUE	1450kN
MIN. FEED RATE	0,8 m/sec
MAX. FEED RATE	0,8 m/sec
FEEDING FORCE	89kN
LIFT FORCE	89kN
MAX. TUBE DIAMETER	114MM
HOLDING FORCE	45kN
HOLDING FORCE (JAW TC)	100kN
OIL TANK	250L
THE COOLER	WATER COOLING
FUEL TANK (OPTIONAL)	100L





TECHNICAL INFORMATION C600

DIMENSIONS AND WEIGHT IN TRANSPORT POSITION

POWER	800x1900x1300MM 1150kg
SKI FRAME	950x2700-3440x1470MM 2100kg
CONTROL PANEL	600x600x100MM 100kg
CROWNING (ELECTRIC MOTOR)	2000x4700x2600MM 5050kg
CROWNING (DISEL MOTOR)	1000x2000x2200MM 6500kg

EXTRA ACCESSORIES AND AUXILIARY EQUIPMENT

MUD PUMP - THREE-PHASE

POWER	HYDRAULIC	DIESEL (119kW) ELECTRIC. (75-90-110kW)
TRANSMISSION	HYDROMOTOR	MUFF
FLOW RATE	80 l/min	135 l/min
MAX. PRESSURE	50 bar	69.9 bar

SYSTEM OIL COOLER AIR

TILT OF THE MAST HYDROCYLINDER

CRAWLER FRAME 300x200cm MADE IN EUROPE

DIESEL DRIVE 22 kW 2 CYLINDERS

CONTROL REMOTE CONTROL

DRILLING EQUIPMENT CORE TUBE FLUSHING
GLAND DRILL BIT

TOTAL MAST LEIGHT	MAST LEIGHT	FEED RATE
3100MM	3000MM	1800MM



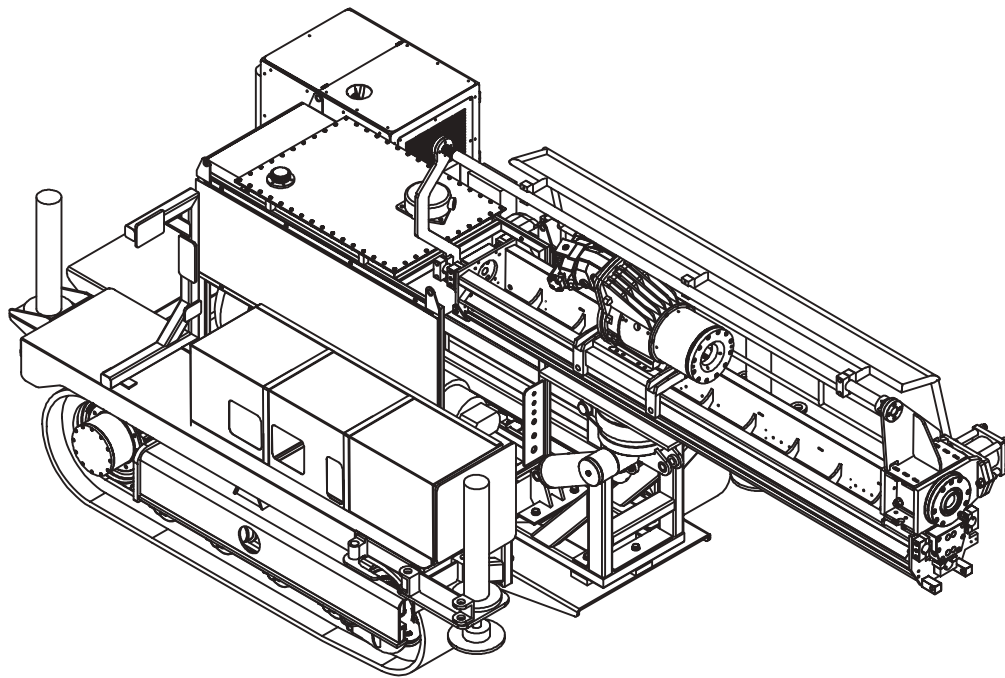
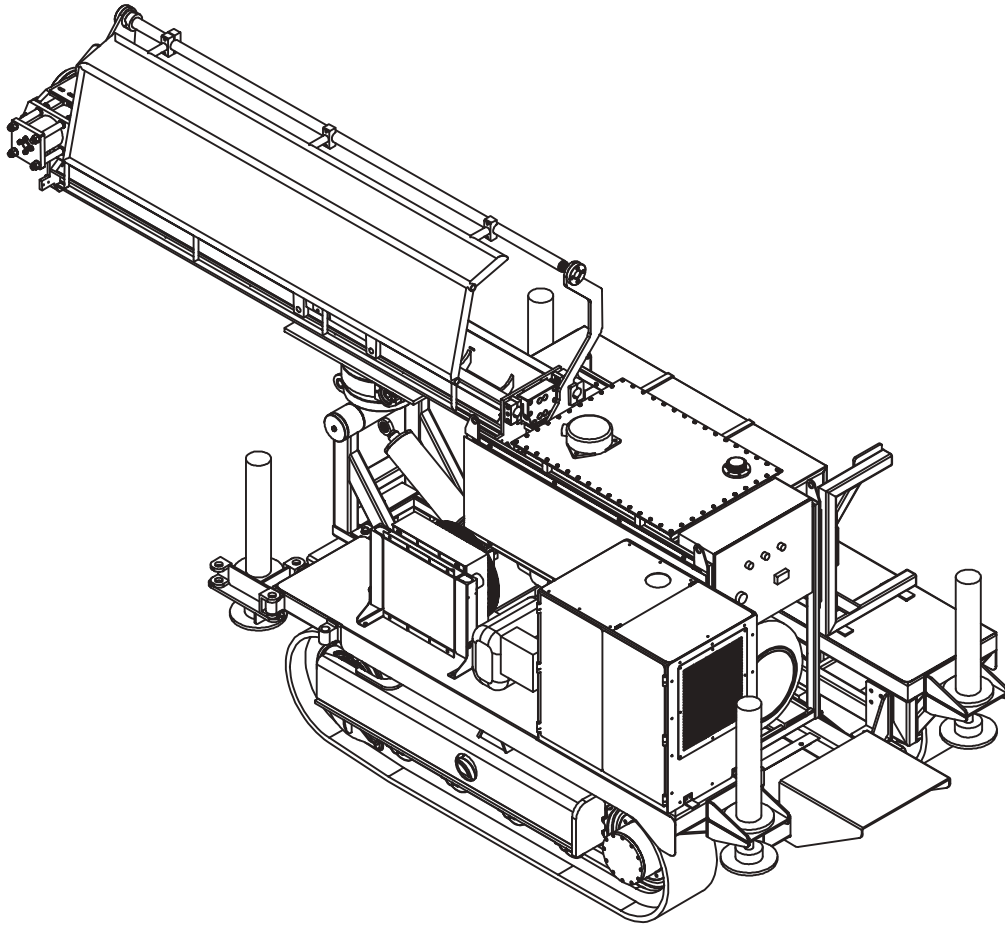

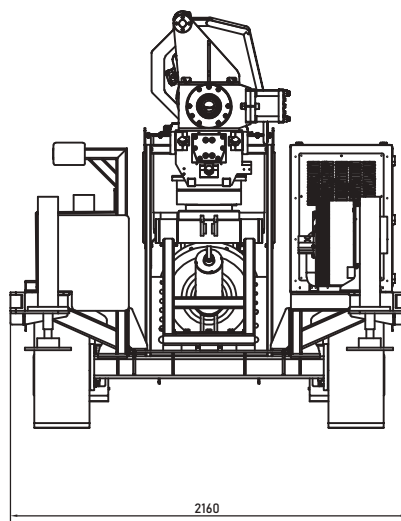
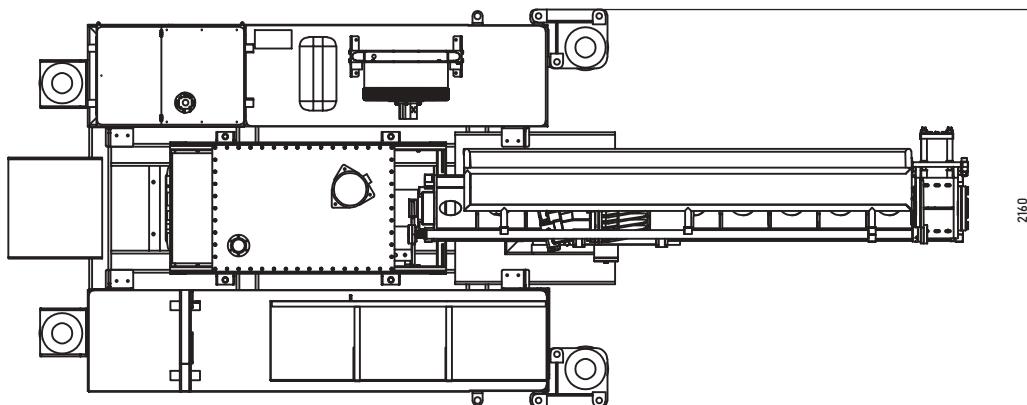
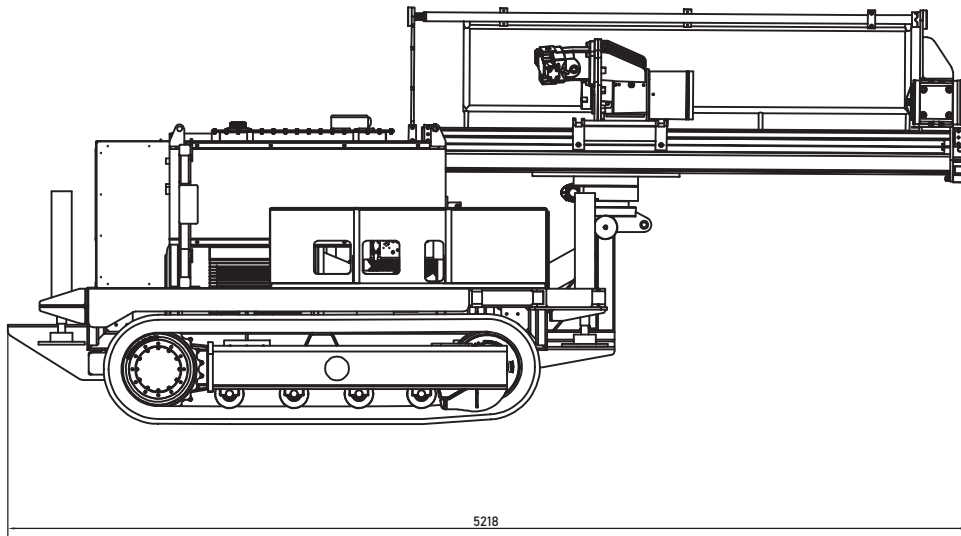



SDS

SOLID DRILLING SOLUTIONS

OUR BRANCHES

BRANCH IN KAZAKHSTAN
SOLID DRILLING SOLUTIONS - QAZAQSTAN",
050059, AL-FARABI AVE. 7 NURLY TAU BUSINESS
CENTER 5A, OFFICE. 171
PHONE: +7 727 225 00 04
EMAIL: INFO@SOLIDDRILLING.KZ

HEAD OFFICE IN TURKEY
SDS MÜŞAVIRLIK MÜHENDISLIK İMALAT İTH.
İHR. SAN. VE TİC. LTD. ŞTİ.
GOLDEN TOWER, MEHMET AKIF ERSOY MAH.
287. SOK. NO:7 /50 KAT:9 06200
YENİMAHALLE ANKARA / TURKEY
PHONE: +90 312 354 83 27
FAX: +90 312 354 83 27
E-MAIL: INFO@SOLIDDRILLING.COM

BRANCH OFFICE IN RUSSIA
SOLID DRILLING SOLUTIONS - RUSSIA", 109428,
RUSSIA, MOSCOW, UL.
RYAZANSKY PROSPEKT 8A,
BLDG. 1, OFFICE 422.
PHONE: +7 925 800 08 52
EMAIL: INFO@SOLIDDRILLING.RU

www.soliddrilling.com